

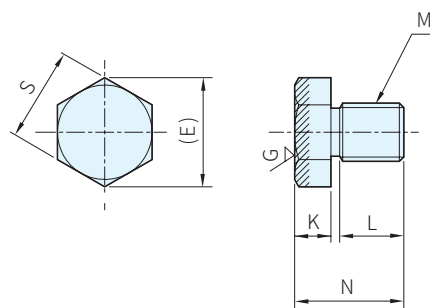

本體	
材質	處理
S45C	無電解鍍

WAT-SBRN

WAT-SBFN

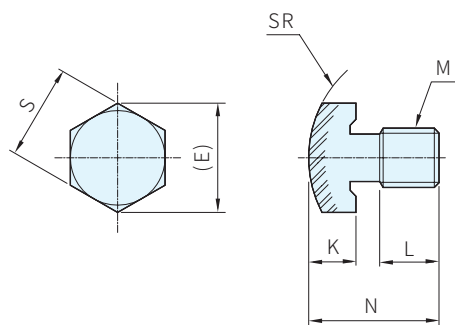

品號	M	L	N	K ±0.01	S	(E)	SR	備註	庫存
WAT-SBRN5M	M5×0.8	5	11.0	4.0	8	9.2	10	斜線部淬火 HRC35以上 拋光研磨	△
WAT-SBRN8M	M8×1	7	15.5	5.5	13	15.0	12		△

品號	M	L	N	K ±0.01	S	(E)	備註	庫存
WAT-SBFN5M	M5×0.8	4.6	10.5	3.5	8	9.2	斜線部淬火 HRC35以上 研磨	△
WAT-SBFN8M	M8×1	7.0	15.0	5.0	13	15.0		△

Ps. 備註

· 螺絲頭部淬火處理

訂貨： 交期：

WAT-SBRN5M